



AJM SureBlend™ PBT 1000 Powdered Polymer Blending and Dosing System - Standard Specification

All AJM SureBlend™ systems are designed and manufactured in Australia.

The AJM Sureblend™ PBT Range has been designed to be a low maintenance powdered polymer blending and dosing system that allows a range of makeup concentrations and dosing rates to be utilised. If in doubt, please contact AJM for clarification of sizing and requirements.

Capacity 1Kg/hr @ 1:500 (0.2%) Dilution

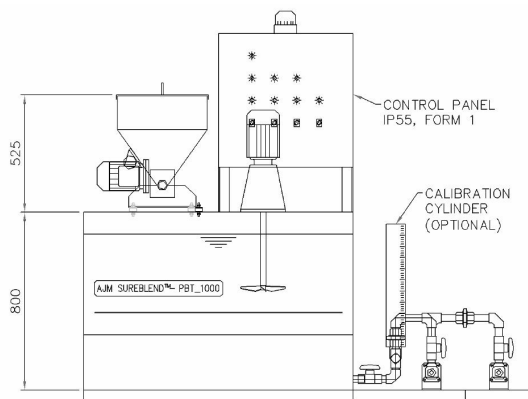

Dimensions mm	
L	1700
W	1900
H	1650

System components

The AJM Sureblend™ PBT 1000 is supplied as a complete system incorporating the following components. These components are pre-assembled and tested prior to dispatch including all interconnecting plumbing and wiring.

Standard specification

Item	Standard specification	Option
Fabricated components		
Blending Tank	304 stainless steel 2B finish	316 stainless steel
Skid	304 stainless steel	316stainless steel
Platform	Galvanised Mild Steel	
Control Panel	Epoxy Painted Mild Steel	304 stainless steel
Screw Feeder	304 stainless steel with vibrator. 50L Hopper.	
Screw Feeder Flight	Mild steel	
Pipework	Class 12 UPVC and Type B Copper	
Major items		
Polymer Dosing Pump	Helical Rotor 50 to 350L/hr Adjustable	Other Flow Rates Available 2 nd Dosing Pump Available
Polymer Mixer	400rpm 316 Stainless Steel wetted parts	

Capacities

Size – 1Kg/hr @ 1:500 (0.2%)

Dilution Range – 1:1000 (0.1%) to 1:200 (0.5%)

Retention – Makeup – 400L

- Ageing – 600L

Electrical

AJM design and manufacture electrical control panels and the units are supplied prewired and tested. All electrics are IP55 to IP56 as standard.

Control Panel Specification

Item	Standard specification	Option
Type	Form 1A	
Protection	IP55	
Control system	Relay logic (Zelio Electronic Relay included)	
Construction	Epoxy coated mild steel	Stainless steel
Alarm System	Audio/Visual with audio Cancel	

Services Required

Power Supply	15 A 415VAC + Neutral and earth
Mains Water	1" supply, 600kPa, with backflow protection
Compressed Air (optional Item)	Intermittent 3cfm @ 500kPa dried air
Protection	Unit should be located in a dry area out of weather.

Wetting System

The AJM SureBlend™ PBT 1000 utilises a slow speed solid shaft screw feeder which meters the powered polymer directly onto the surface of the blending tank. The polymer is then immediately drawn into the mixer vortex. This system guarantees full individual wetting of the powder granules (thus insuring the absence of “fish eyes”).

Options

- Upgrade of tank and skid to 316 Stainless Steel
- Upgrade of panel to Stainless Steel
- 2nd Dosing Pump (configured duty/standby or individual duty)
- 2000 or 5000mL Calibration Cylinder for dosing pumps
- Air Purge of feeder discharge (for humid application areas)

AJM Contact details

Web Site www.ajmenviro.com.au
Email technical tech@ajmenviro.com.au
Email sales sales@ajmenviro.com.au

AJM Environmental Services
4/398 The Boulevard
Kirrawee NSW 2232
Tel: 61 2 9542 2355
Fax: 61 2 9542 2433

Disclaimer: This specification sheet has been created with the greatest care and attention however it is possible that some information is either incomplete or out of date. AJM are continuously updating and improving our products and services. Please contact our offices for more detailed or updated specifications as we cannot be held responsible for any errors resulting from the use of the information supplied herein.